

Description

The MC1XDZR03-HP1 mounting card is designed to host a DZR or DZXR series DigiFlex® Performance™ digital servo drive. The drive plugs into the bottom side of the mounting card, providing a compact assembly with connectors and switches readily accessible. The MC1XDZR03-HP1 is ideal for prototyping and integrating a DZR or DZXR series digital servo drive in your machine.

The MC1XDZR03-HP1 utilizes side-entry right angle fixed screw terminals for the Motor and Power connectors. For vertical-entry quick-disconnect Motor and Power connections use the MC1XDZR03-QD mounting card.

The MC1XDZR03-HP1 is designed to host DZR and DZXR drive models with a 60 amp peak current rating (-060L080 models). Drives with a lower peak current rating may be used with the MC1XDZR03-HP1, although *ADVANCED* Motion Controls recommends the MC1XDZR03 or MC1XDZR03-QD for other drive models.

Drive Compatibility*

DZ (Standard Environment)	DZX (Extended Environment)
80 V Models	80 V Models
60A	40A
40A	15A
20A	8A
12A	

*For 175 V DZ drive models, use MC1XDZR03 or MC1XDZR03-QD mounting card models.

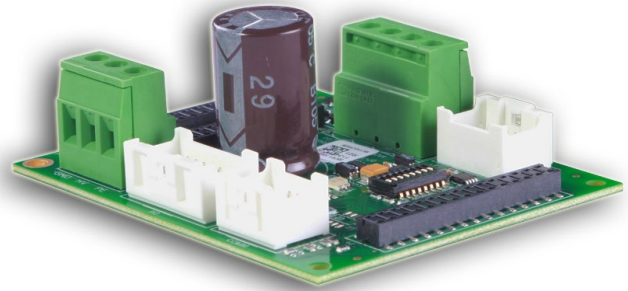

Features

- ▲ Mounts DZR- and DZXR-Series DigiFlex® Performance™ Digital Servo Drives
- ▲ Single Axis Mounting Card
- ▲ On-board Signal Conditioning
- ▲ On-board DIP Switches for Configuration and Communication Settings

DESIGNED FOR

- DZRALTE-060L080

ADDITIONAL DRIVES SUPPORTED

- DZRALTE-012L080
- DZRALTE-020L080
- DZRALTE-040L080
- DZXRALTE-008L080
- DZXRALTE-015L080
- DZXRALTE-040L080

FEEDBACK SUPPORTED

- Incremental Encoder
- Hall Sensors
- Auxiliary Incremental Encoder

COMPLIANCES & AGENCY APPROVALS

- RoHS II

BLOCK DIAGRAM & SPECIFICATION SUMMARY

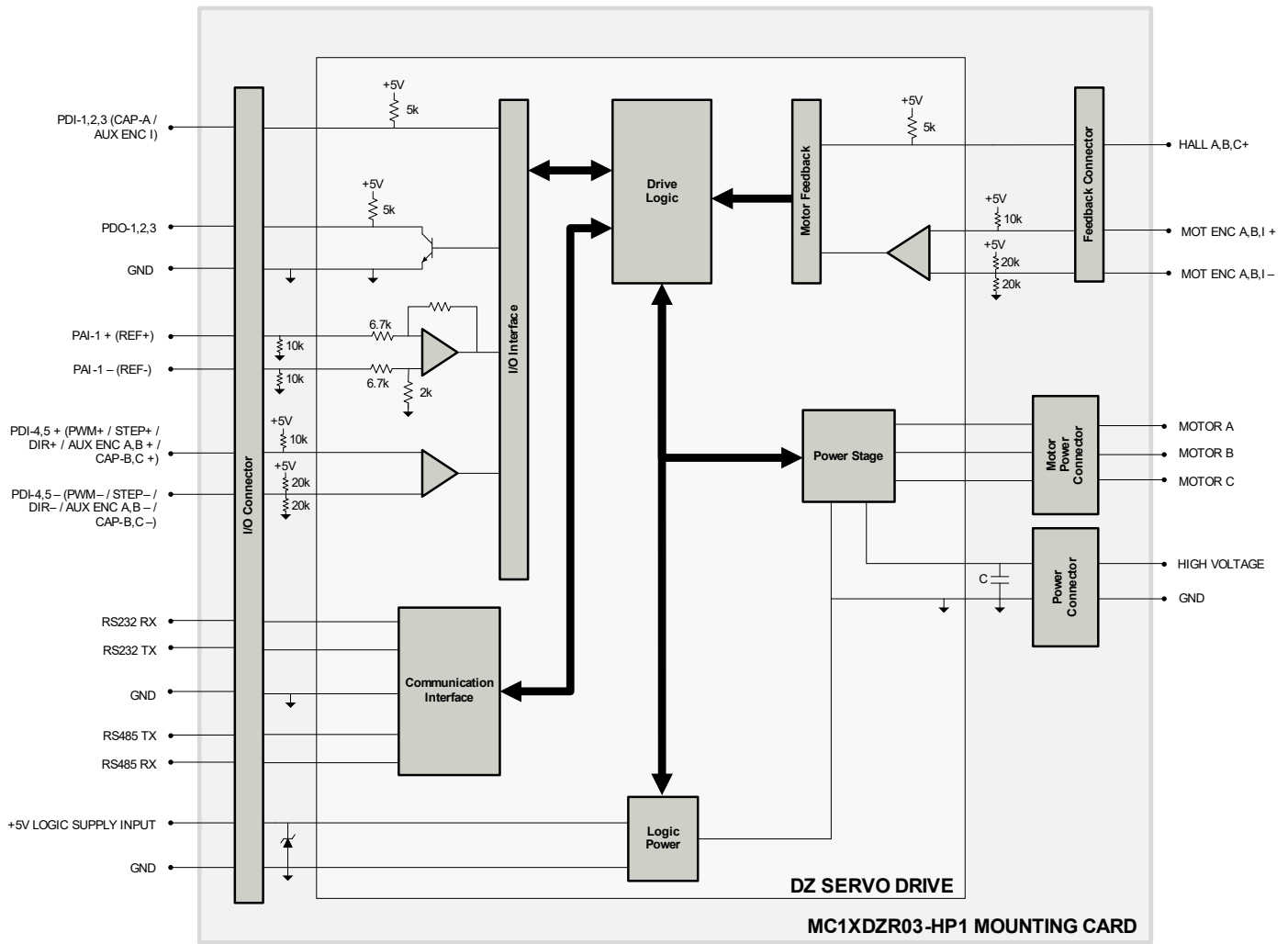

Mechanical Specifications

Mounting Signal Connector: P1	30-pin, dual-row, 2.54 mm pitch socket
Mounting Power Connector: P2	24-pin, dual-row, 2.54 mm pitch socket
Mounting Power Connector: P3	24-pin, dual-row, 2.54 mm pitch socket
I/O Connector: P4*	16-port, dual-row, 2.00 mm spaced plug terminal
Communication Connector: P5*	10-port, dual-row, 2.00 mm spaced plug terminal
Feedback Connector: P6*	12-port, dual-row, 2.00 mm spaced plug terminal
Motor Power Connector: P7	4-port, 5.08 mm spaced fixed screw terminal
Power Connector: P8	3-port, 5.08 mm spaced fixed screw terminal
Bus Capacitance	470 μ F / 100 V
Size (L x W x H)	2.5 x 3.0 x 1.2 inches
Weight	50.7 g (1.8 oz)

***Mating Connector Kit**

Mating connector housing and crimp pins can be ordered as a kit using *ADVANCED* Motion Controls part number **KC-MC1XDZ02**. This includes mating connector housing and crimp style contacts for the I/O, Feedback, and Communication connectors. The recommended tool for crimping the contacts is Molex part number **63811-6300**.

PIN FUNCTIONS

P1 – Mounting Signal Connector

This connector mates directly to the drive. For pin functions refer to the drive datasheet.

P2 – Mounting Power Connector

This connector mates directly to the drive. For pin functions refer to the drive datasheet.

P3 – Mounting Power Connector

This connector mates directly to the drive. For pin functions refer to the drive datasheet.

P4 – I/O Connector

Pin	Name	Description	I/O
1	+5V LOGIC	+5V Logic Supply Input ($\pm 5\%$)	I
2	GND	Ground	GND
3	PDI-3	Programmable digital input 3, or High Speed Capture A, or Aux Enc I	I
4	PAI-1 + (REF +)	Differential reference signal input, 12-bit resolution. Can also be used as programmable analog input 1.	I
5	PDI-2	Programmable digital input 2	I
6	PAI-1 - (REF -)	Differential reference signal input, 12-bit resolution. Can also be used as programmable analog input 1.	I
7	PDI-1	Programmable digital input 1	I
8	PDO-3	Programmable digital output 3	O
9	GND	Ground	GND
10	PDO-2	Programmable digital output 2	O
11	PDI-5 +	Programmable, differential digital input or Direction+ or Aux Enc B+ or Capture C+	I
12	PDO-1	Programmable digital output 1	O
13	PDI-5 -	Programmable, differential digital input or Direction- or Aux Enc B- or Capture C-	I
14	PDI-4 +	Programmable differential digital input, or PWM+ or Step+ or Aux Enc A+ or Capture B+	I
15	GND	Ground	GND
16	PDI-4 -	Programmable differential digital input, or PWM- or Step- or Aux Enc A- or Capture B-	I

P5 – Communication Connector

Pin	Name	Description	I/O
1	2-WIRE RS485 JUMPER	For RS-485 2-Wire system, attach a jumper between pins 1 and 2. Also attach a jumper between pins 3 and 4.	-
2	2-WIRE RS485 JUMPER		-
3	RS232 RX	RS-232 Receive/Transmit. Connect pin 3 to TX port on PC. Connect pin 4 to RX port on PC. For RS-485 2-Wire system, attach a jumper between pins 3 and 4.	I/O
4	RS232 TX		I/O
5	GND	Ground	GND
6	GND		GND
7	RS485 RX-	Receive Line (RS-485)	I/O
8	RS485 TX-	Transmit Line (RS-485)	I/O
9	RS485 RX+	Receive Line (RS-485)	I/O
10	RS485 TX+	Transmit Line (RS-485)	I/O

P6 – Feedback Connector			
Pin	Name	Description	I/O
1	HALL B	Commutation Sensor Inputs.	I
2	HALL A	Commutation Sensor Inputs.	I
3	MOT ENC A+	Differential Encoder A Channel Input	I
4	HALL C	Commutation Sensor Inputs.	I
5	MOT ENC A-	Differential Encoder A Channel Input (for single-ended signals use only the positive input)	I
6	GND	Ground	GND
7	+5V OUT	+5V Encoder Supply Output	O
8	MOT ENC B+	Differential Encoder B Channel Input	I
9	MOT ENC I+	Differential Encoder Index Input	I
10	MOT ENC B-	Differential Encoder B Channel Input (for single-ended signals use only the positive input)	I
11	MOT ENC I-	Differential Encoder Index Input (for single-ended signals use only the positive input)	I
12	GND	Ground	GND

P7 – Motor Power Connector			
Pin	Name	Description	I/O
1	MOTOR A	Motor phase A	O
2	MOTOR B	Motor phase B	O
3	MOTOR C	Motor phase C	O
4	PE	Protective Earth Ground (motor cable shield)	PE

P8 –Power Connector			
Pin	Name	Description	I/O
1	PE	Protective Earth Ground	PE
2	HIGH VOLTAGE	DC Power Input	I
3	POWER GND	Power Ground (Common with Signal Ground)	GND

BOARD CONFIGURATION

DIP Switch Functions

Drive Address Settings

Node-ID	SW1	SW2	SW3	SW4	SW5	SW6
Load from non-volatile memory	OFF	OFF	OFF	OFF	OFF	OFF
1	ON	OFF	OFF	OFF	OFF	OFF
2	OFF	ON	OFF	OFF	OFF	OFF
3	ON	ON	OFF	OFF	OFF	OFF
...
63	ON	ON	ON	ON	ON	ON

RS485 Bit Rate Settings

Bit Rate (bits/sec)	SW7
Load from non-volatile memory	OFF
9.6K	ON

RS485 Termination Node Selection

Note that both SW8 and SW9 must be set ON to terminate the last device on the network.

RS485 Termination	SW8	SW9
Not Terminated	OFF	OFF
Terminated	ON	ON

LED Functions

The MC1XDZR03-HP1 contains LEDs that indicate DC Power and Logic power supply status. The Power LED will light up when power is applied to P8-Power Connector, and the Logic LED will light up when the +5 VDC Logic Power is applied to P4-I/O Connector.

Mounting Configuration

Note that a DZ servo drive plugs into the MC1XDZR03-HP1 from the underside of the mounting card to allow easy access to the mounting card switches and connectors. The drive and mounting card assembly can be secured to a panel or heatsink through the mounting holes in the drive baseplate, or with standoffs at the four mounting holes in the corners of the mounting card (standoff height must be at least 22.11mm for DZ-012L080 drive models, and 26.65mm for all other drive models).

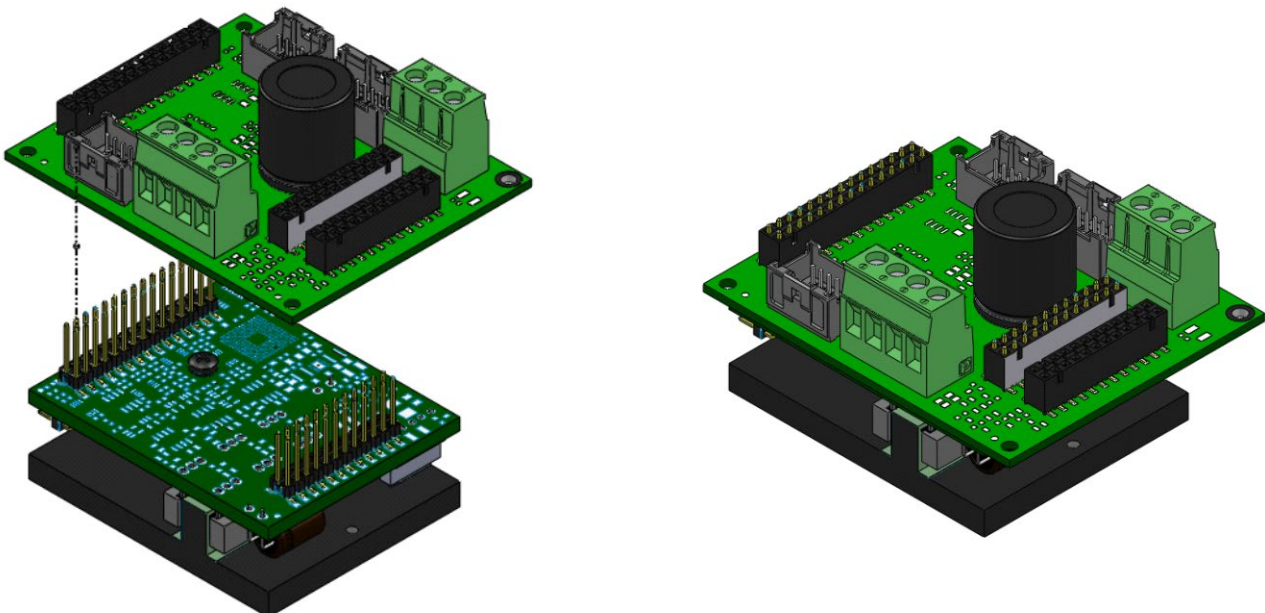

CONNECTOR INFORMATION

P1 – Mounting Signal Connector

Connector Information	30-pin, dual-row, 2.54 mm pitch header
Mating Connector Example	No Mating Connector Required. Mate directly to drive

P2 – Mounting Power Connector

Connector Information	24-pin, dual-row, 2.54 mm pitch header
Mating Connector Example	No Mating Connector Required. Mate directly to drive

P3 – Mounting Power Connector

Connector Information	24-pin, dual-row, 2.54 mm pitch header
Mating Connector Example	No Mating Connector Required. Mate directly to drive

P4 – I/O Connector

Connector Information	16-port, dual-row, 2.00 mm spaced plug terminal, vertical mount	
Mating Connector	Details	Molex: P/N 51353-1600 (housing); 56134-9100 (contacts)
	Included with Card	No

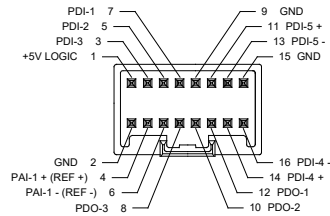

P5 – Communication Connector

Connector Information	10-port, dual-row, 2.00 mm spaced plug terminal, vertical mount	
Mating Connector	Details	Molex: P/N 51353-1000 (housing); 56134-9100 (contacts)
	Included with Card	No

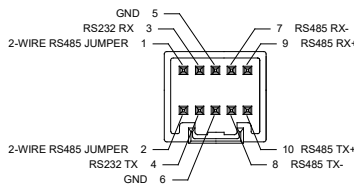

P6 – Feedback Connector

Connector Information		12-port, dual-row, 2.00 mm spaced plug terminal, vertical mount
Mating Connector	Details	Molex: P/N 51353-1200 (housing); 56134-9100 (contacts)
	Included with Card	No

Diagram labels for P6 Feedback Connector:

- 5: MOT ENC A-
- 3: MOT ENC A+
- 1: HALL B
- 7: +5V OUT
- 9: MOT ENC I+
- 11: MOT ENC I-
- 2: HALL A
- 4: HALL C
- 6: GND
- 12: GND
- 10: MOT ENC B-
- 8: MOT ENC B+

P7 – Motor Power Connector

Connector Information		4-port, 5.08 mm spaced fixed screw terminal
Mating Connector	Details	Not Applicable
	Included with Card	Not Applicable

Diagram labels for P7 Motor Power Connector:

- 4: PE
- 3: MOTOR C
- 2: MOTOR B
- 1: MOTOR A

P8 –Power Connector

Connector Information		3-port, 5.08 mm spaced fixed screw terminal
Mating Connector	Details	Not Applicable
	Included with Card	Not Applicable

Diagram labels for P8 Power Connector:

- 3: POWER GND
- 2: HIGH VOLTAGE
- 1: PE

MOUNTING DIMENSIONS

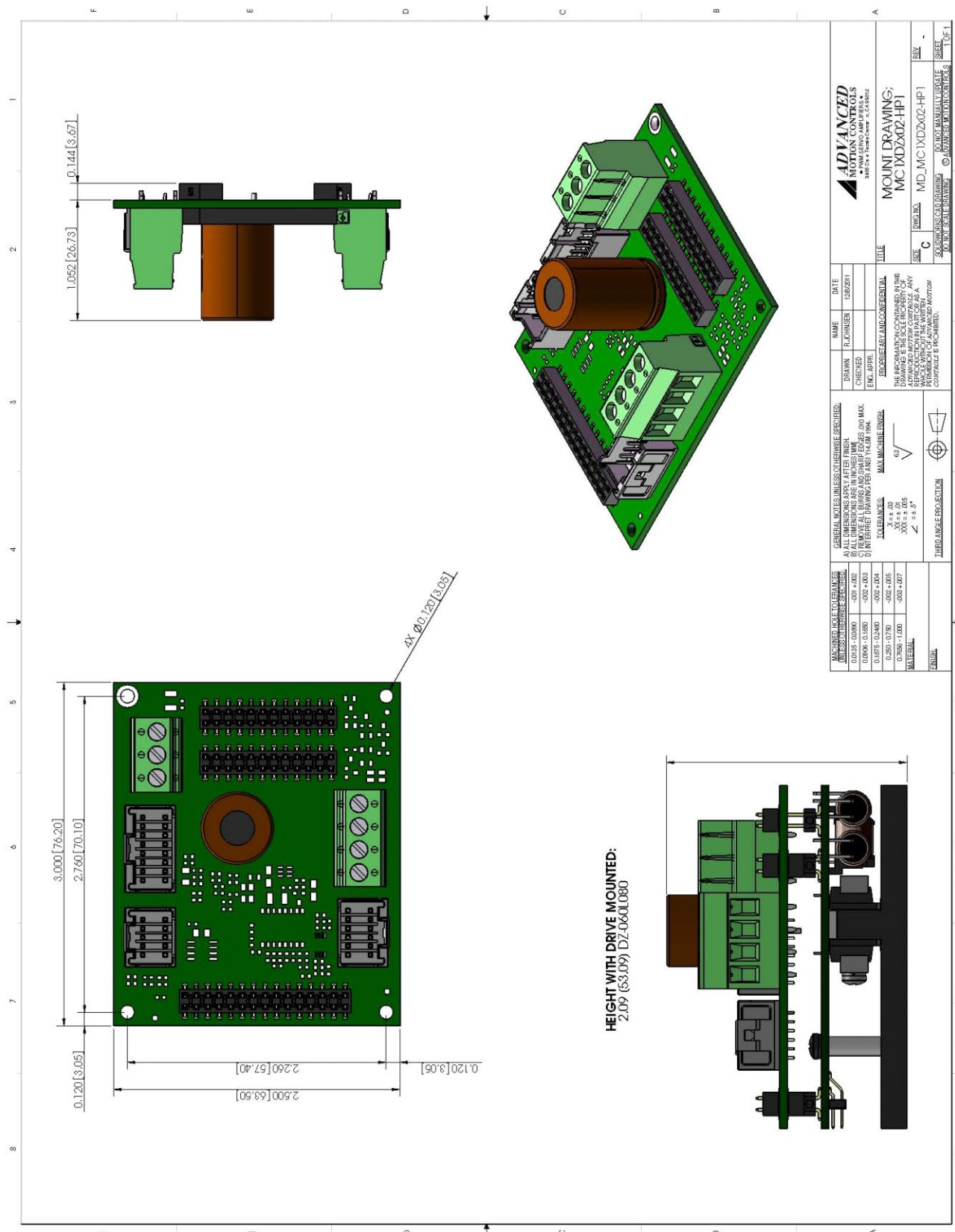

PART NUMBERING INFORMATION

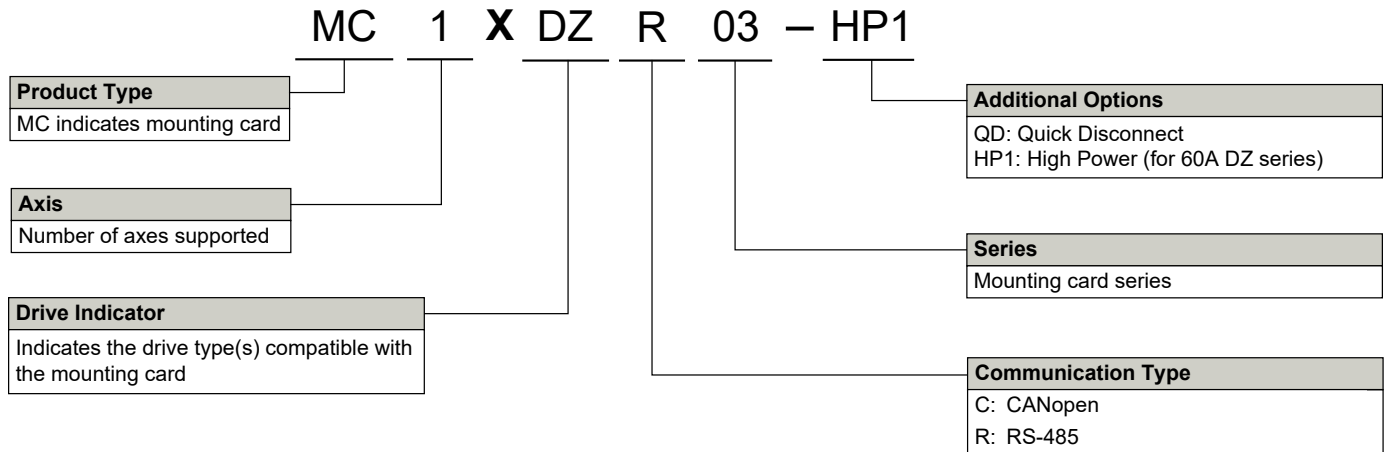

DigiFlex® Performance™ series of products are available in many configurations. All models listed in the selection tables of the website are readily available, standard product offerings.

ADVANCED Motion Controls also has the capability to promptly develop and deliver specified products for OEMs with volume requests. Our Applications and Engineering Departments will work closely with your design team through all stages of development in order to provide the best servo drive solution for your system. Equipped with on-site manufacturing for quick-turn customs capabilities, ADVANCED Motion Controls utilizes our years of engineering and manufacturing expertise to decrease your costs and time-to-market while increasing system quality and reliability.

Examples of Customized Products

- | | |
|--|--|
| <ul style="list-style-type: none"> ▲ Optimized Footprint ▲ Private Label Software ▲ OEM Specified Connectors ▲ No Outer Case ▲ Increased Current Resolution ▲ Increased Temperature Range ▲ Custom Control Interface ▲ Integrated System I/O | <ul style="list-style-type: none"> ▲ Tailored Project File ▲ Silkscreen Branding ▲ Optimized Base Plate ▲ Increased Current Limits ▲ Increased Voltage Range ▲ Conformal Coating ▲ Multi-Axis Configurations ▲ Reduced Profile Size and Weight |
|--|--|

Feel free to contact Applications Engineering for further information and details.

^AAll specifications in this document are subject to change without written notice. Actual product may differ from pictures provided in this document.