

**Description**

The MC1XDZPC01 mounting card is designed to host a DZCANTU series DigiFlex® Performance™ digital servo drive. The drive plugs into the bottom side of the mounting card, providing a compact assembly with connectors and switches readily accessible. The MC1XDZPC01 is ideal for prototyping and integrating a DZCANTU series digital servo drive in your machine.

The MC1XDZPC01 utilizes side-entry right angle fixed screw terminals for the motor and power connectors, and quick-disconnect signal, feedback, and communication connectors. A dedicated connector for STO is also included.

DZCANTU series DigiFlex® Performance™ digital servo drives communicate on a CANopen network.

**Drive Compatibility**

**DZCANTU Drive Models**

**80V Drive Models**

- 40A
- 20A

**175V Drive Models**

- 20A



**Features**

- ▲ Mounts DZCANTU DigiFlex® Performance™ Digital Servo Drives
- ▲ Single Axis Mounting Card
- ▲ On-board CANopen Transceiver for CANopen Communication

**DRIVES SUPPORTED**

- DZCANTU-020B080
- DZCANTU-040B080
- DZCANTU-020B200

**FEEDBACK SUPPORTED (DRIVE FIRMWARE DEPENDENT)**

- Incremental Encoder
- Auxiliary Incremental Encoder
- Hall Sensors
- 1Vp-p Sine/Cosine Encoder
- Absolute Encoder (EnDat® 2.1, Hiperface®, or BiSS C-Mode)
- ±10 VDC Position
- Tachometer (±10 VDC)

**COMPLIANCES & AGENCY APPROVALS**

- RoHS II

**BLOCK DIAGRAM & SPECIFICATION SUMMARY**

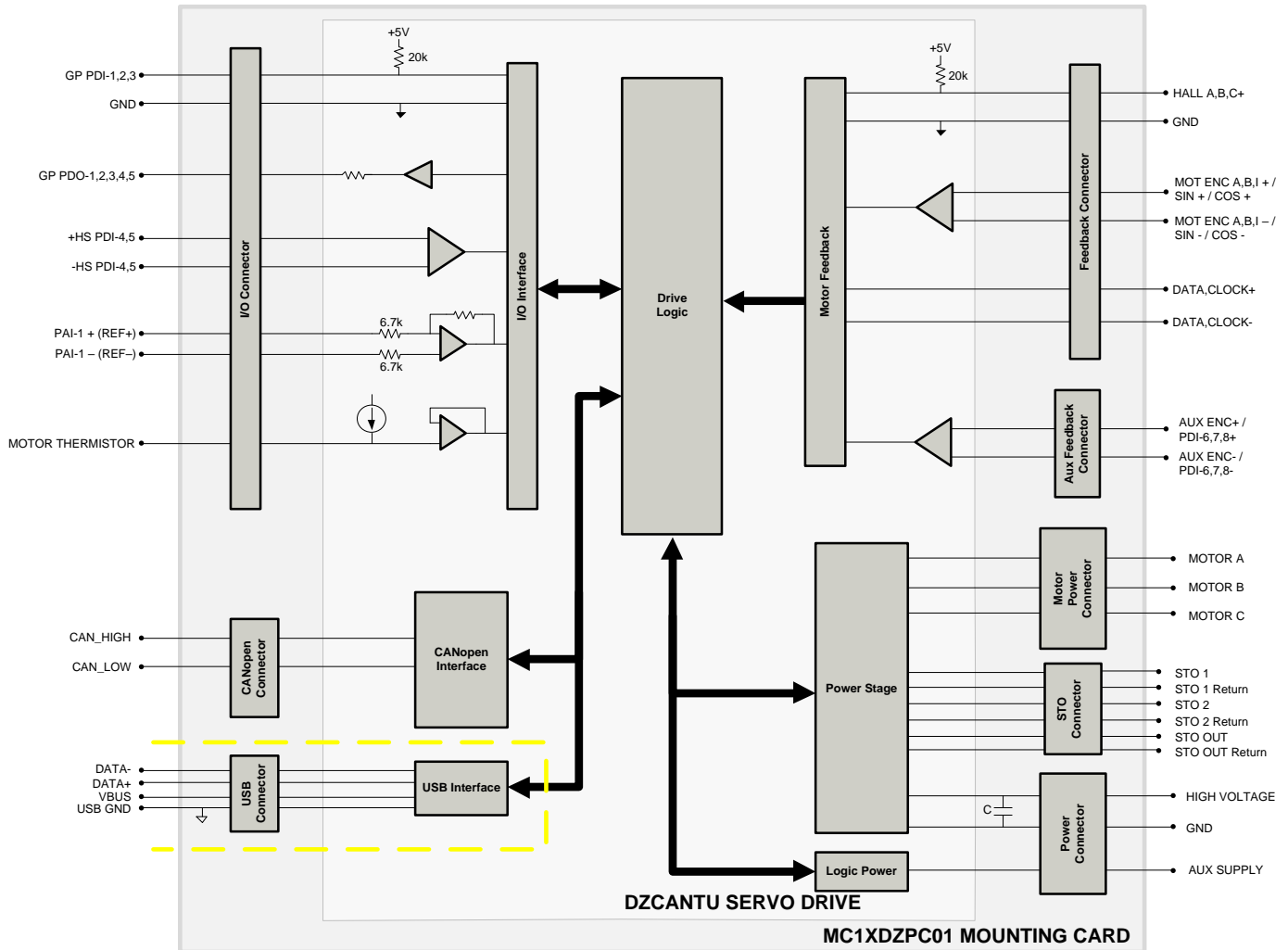

**Mechanical Specifications**

Mounting Signal Connector: Mates Directly to Drive	96-port, 1.27mm spaced, dual-row socket
Mounting Power Connector: Mates Directly to Drive	58-pin, 2.0mm spaced, dual-row socket
Motor Power Connector: P1	4-port screw terminal
Power Connector: P2	4-port screw terminal
CANopen Communication Connector: P5*	8-pin, dual-row, 2.00 mm spaced plug terminal, vertical mount
USB Connector: P6	5-pin, Mini USB B Type port
I/O Connector: P7*	20-pin, dual-row, 2.00 mm spaced plug terminal, vertical mount
Auxiliary Feedback Connector: P8*	10-pin, dual-row, 2.00 mm spaced plug terminal, vertical mount
Feedback Connector: P9*	18-pin, dual-row, 2.00 mm spaced plug terminal, vertical mount
STO Connector: P10*	8-port, 2.0 mm spaced, enclosed, friction lock header
Size (L x W x H) / mm (in)	63.5 x 88.9 x 26.3 (2.5 x 3.5 x 1.0)
Weight / g (oz)	68 (2.4)

**\*Mating Connector Kit**

Mating connector housing and crimp pins can be ordered as a kit using *ADVANCED* Motion Controls part number **KC-MC1XDZP01**. This includes mating connector housing and crimp style contacts for the I/O, Feedback, Auxiliary Feedback, STO, and Communication connectors. The recommended tool for crimping the contacts is Molex part number **63811-6300**.

## PIN FUNCTIONS

### Mounting Signal Connector

This connector mates directly to the drive. For pin functions refer to the drive datasheet.

### Mounting Power Connector

This connector mates directly to the drive. For pin functions refer to the drive datasheet.

### P1 – Motor Power Connector

Pin	Name	Description / Notes	I/O
1	MOTOR C	Motor Phase C	O
2	MOTOR B	Motor Phase B	O
3	MOTOR A	Motor Phase A	O
4	CHASSIS	Shield Connection	-

### P2 - Power Connector

Pin	Name	Description / Notes	I/O
1	CHASSIS	Shield Connection	-
2	AUX SUPPLY	Logic Supply	I
3	GND	Ground	GND
4	HV	DC Power Supply	I

### P5 – CANopen Communication Connector

Pin	Name	Description / Notes	I/O
1	CAN_H	CAN_H bus line (dominant high)	I/O
2	CAN_H		I/O
3	CAN_L	CAN_L bus line (dominant low)	I/O
4	CAN_L		I/O
5	GND	Ground	GND
6	GND		GND
7	RESERVED	Reserved	-
8	RESERVED		-

### P6 - USB Communication Connector

Pin	Name	Description / Notes	I/O
1	VBUS	Supply Voltage	O
2	DATA -	USB Data -	I/O
3	DATA +	USB Data +	I/O
4	RESERVED	Reserved	-
5	GND	USB Ground	UGND

### P7 – I/O Connector

Pin	Name	Description	I/O
1	CHASSIS	Shield Connection	-
2	RESERVED	Reserved	-
3	PDI-1	Programmable Digital Input	I
4	PDI-4+	High Speed Differential Programmable Digital Input	I
5	PDI-2	Programmable Digital Input	I
6	PDI-4-	High Speed Differential Programmable Digital Input	I
7	PDI-3	Programmable Digital Input	I
8	PDI-5+	High Speed Differential Programmable Digital Input	I
9	RESERVED	Reserved	-
10	PDI-5-	High Speed Differential Programmable Digital Input	I
11	PDO-1	Programmable Digital Output	O
12	RESERVED	Reserved	-
13	PDO-2	Programmable Digital Output	O
14	+5V OUT	+5V Output from Logic Supply	O
15	PDO-3	Programmable Digital Output	O
16	GND	Ground	GND
17	PDO-4	Programmable Digital Output	O
18	PAI-1+	Differential Programmable Analog Input or Reference Signal Input (12-bit resolution)	I
19	PDO-5	Programmable Digital Output	O
20	PAI-1-	Differential Programmable Analog Input or Reference Signal Input (12-bit resolution)	I

**P8 – Auxiliary Feedback Connector**

Pin	Name	Description	I/O
1	CHASSIS	Shield Connection	-
2	RESERVED	Reserved	-
3	AUX ENC I+	Auxiliary Incremental Encoder Channel I or Differential Programmable Digital Input 8	I
4	AUX ENC A+	Auxiliary Incremental Encoder Channel A or Differential Programmable Digital Input 6	I
5	AUX ENC I-	Auxiliary Incremental Encoder Channel I or Differential Programmable Digital Input 8	I
6	AUX ENC A-	Auxiliary Incremental Encoder Channel A or Differential Programmable Digital Input 6	I
7	+5V USER	+5V User Supply Output (current shared with pin P9-17)	O
8	AUX ENC B+	Auxiliary Incremental Encoder Channel B or Differential Programmable Digital Input 7	I
9	GND	Ground	GND
10	AUX ENC B-	Auxiliary Incremental Encoder Channel B or Differential Programmable Digital Input 7	I

**P9 – Feedback Connector\***

Pin	Incremental Encoder	Absolute Encoder	1Vp-p Sin/Cos Encoder	Description / Notes	I/O
1	CHASSIS	CHASSIS	CHASSIS	Shield Connection	-
2	RESERVED	RESERVED	RESERVED	Reserved	-
3	MOT ENC I+	RESERVED	RESERVED	Differential Encoder Index	I
4	MOT ENC A+	SIN+	SIN+	Differential Encoder A / Differential Sine Input	I
5	MOT ENC I-	RESERVED	RESERVED	Differential Encoder Index	I
6	MOT ENC A-	SIN-	SIN-	Differential Encoder A / Differential Sine Input	I
7	HALL A	RESERVED	HALL A	Commutation sensor input.	I
8	MOT ENC B+	COS+	COS+	Differential Encoder B/ Differential Cosine Input	I
9	HALL B	RESERVED	HALL B	Commutation sensor input.	I
10	MOT ENC B-	COS-	COS-	Differential Encoder B/ Differential Cosine Input	I
11	HALL C	RESERVED	HALL C	Commutation sensor input.	I
12	RESERVED	CLK+	RESERVED	Differential Clock Line	-
13	MOTOR THERMISTOR	MOTOR THERMISTOR	MOTOR THERMISTOR	Motor Thermal Protection	I/O
14	RESERVED	CLK-	RESERVED	Differential Clock Line	I/O
15	+5V USER	+5V USER	+5V USER	+5V User Supply Output (current shared with pin P8-7)	I/O
16	RESERVED	DATA+	RESERVED	Differential Data Line	I/O
17	GND	GND	GND	Ground	GND
18	RESERVED	DATA-	RESERVED	Differential Data Line	I/O

\*Note: Feedback supported (Incremental Encoder, Absolute Sin/Cos Encoder, or 1Vp-p Sin/Cos Encoder) will be dependent on drive firmware.

**P10 – Safe Torque Off (STO) Connector\***

Pin	Name	Description / Notes	I/O
1	STO OUTPUT	Safe Torque Off Output	O
2	STO 5V DISABLE	5V Supply Output for STO Disable. Internal use only.	O
3	STO-1 RETURN	Safe Torque Off 1 Return	STORET1
4	STO-1	Safe Torque Off – Input 1	I
5	STO-2 RETURN	Safe Torque Off 2 Return	STORET2
6	STO-2	Safe Torque Off – Input 2	I
7	STO GND DISABLE	Ground for STO Disable. Internal use only.	GND
8	STO OUT RETURN	Safe Torque Off Output Return	STORETO

\*Note: A dedicated STO Disable Key connector is included and should be installed for applications where STO is not required.

## BOARD CONFIGURATION

### CANopen Node ID Switches

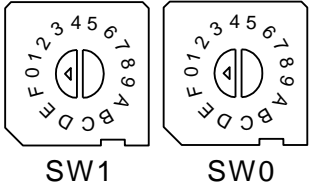
Switch Diagram	Description																								
	<p>Hexadecimal switch settings correspond to the CANopen Node ID. Allowable CANopen Node ID range using the rotary switches is 1 - 63. Node IDs above 63 can be set via DriveWare® or network commands and stored to NVM (up to a Node ID of 127). Setting the rotary switches to zero will use the address stored in NVM.</p> <table border="1"> <thead> <tr> <th>SW1</th> <th>SW0</th> <th>Node ID</th> </tr> </thead> <tbody> <tr> <td>0</td> <td>0</td> <td>Address store in NVM</td> </tr> <tr> <td>0</td> <td>1</td> <td>001</td> </tr> <tr> <td>0</td> <td>2</td> <td>002</td> </tr> <tr> <td>...</td> <td>...</td> <td>...</td> </tr> <tr> <td>3</td> <td>D</td> <td>61</td> </tr> <tr> <td>3</td> <td>E</td> <td>62</td> </tr> <tr> <td>3</td> <td>F</td> <td>63</td> </tr> </tbody> </table>	SW1	SW0	Node ID	0	0	Address store in NVM	0	1	001	0	2	002	...	...	...	3	D	61	3	E	62	3	F	63
SW1	SW0	Node ID																							
0	0	Address store in NVM																							
0	1	001																							
0	2	002																							
...	...	...																							
3	D	61																							
3	E	62																							
3	F	63																							

### CANopen Bit Rate Jumpers

The CANopen bit rate is controlled by jumpers JF12 and JF13, located near the USB communication connector, P6. Use the table below to configure the bit rate.

Bit Rate (kbits/sec)	JF12	JF13
Load from non-volatile memory	Not Installed	Not Installed
500	Installed	Not Installed
250	Not Installed	Installed
125	Installed	Installed

### CANopen Termination Node Jumper

CANopen bus termination is controlled by jumper JF1. The last device in a CAN network requires a termination resistor across the CAN\_H and CAN\_L lines. JF1 is located near the CANopen communication connector, P5.

CANopen Termination	JF1
Non-terminating Node	Not Installed
Terminating Node	Installed

### LED Functions

The MC1XDZPC01 contains LEDs that indicate DC Power Supply status, Logic Power Supply status, and the drive Bridge status. The Power LED (P) will light up green when power is applied to P2-Power Connector, and the Logic LED (L) will light up green when the Logic Power is applied to P3-Auxiliary Logic Connector. The Bridge Status LED (STS) indicates the servo drive's power bridge state, and will be green when the drive is enabled, and red when the drive is in a fault state.

**CONNECTOR INFORMATION**

**Mounting Signal Connector**

Connector Information	96-pin, 1.27 mm spaced, dual-row socket
Mating Connector Example	No Mating Connector Required. Mate directly to drive

**Mounting Power Connector**

Connector Information	58-pin, 2.0 mm spaced, dual-row socket
Mating Connector Example	No Mating Connector Required. Mate directly to drive

**P1 – Motor Power Connector**

Connector Information	4-port screw terminal	
Mating Connector	Details	Not Applicable
	Included with Card	Not Applicable

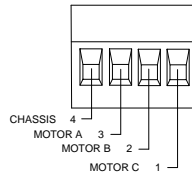

**P2 – Power Connector**

Connector Information	4-port screw terminal	
Mating Connector	Details	Not Applicable
	Included with Card	Not Applicable

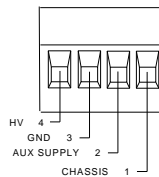

**P5 – CANopen Communication Connector**

Connector Information	8-pin, dual-row, 2.00 mm spaced plug terminal, vertical mount	
Mating Connector	Details	Molex: P/N 51353-0800 (housing); 56134-9100 (contacts)
	Included with Card	No

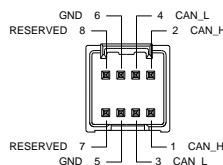

**P6 – USB Connector**

Connector Information		5-pin, Mini USB B Type port
Mating Connector	Details	TYCO: 1496476-3 (2-meter STD-A to MINI-B ASSY)
	Included with Card	No

**P7 – I/O Connector**

Connector Information		20-pin, dual-row, 2.00 mm spaced plug terminal, vertical mount
Mating Connector	Details	Molex: P/N 51353-2000 (housing); 56134-9100 (contacts)
	Included with Card	No

**P8 – Auxiliary Feedback Connector**

Connector Information		10-pin, dual-row, 2.00 mm spaced plug terminal, vertical mount
Mating Connector	Details	Molex: P/N 51353-1000 (housing); 56134-9100 (contacts)
	Included with Card	No

**P9 – Feedback Connector**

Connector Information		18-pin, dual-row, 2.00 mm spaced plug terminal, vertical mount
Mating Connector	Details	Molex: P/N 51353-1800 (housing); 56134-9100 (contacts)
	Included with Card	No

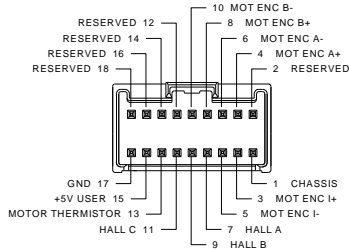

**Incremental Encoder**

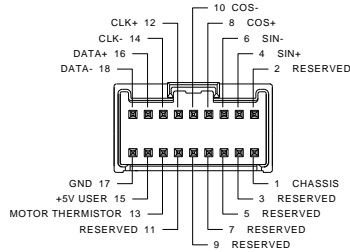

**Absolute Encoder**

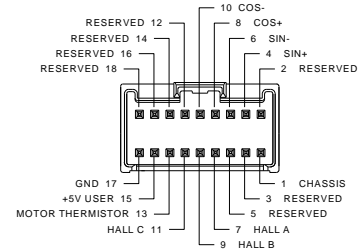

**1Vp-p Sin/Cos Encoder**

**STO – Safe Torque Off Connector**

Connector Information		8-port, 2.00 mm spaced, enclosed, friction lock header
Mating Connector	Details	Molex: P/N 51110-0860 (housing); 50394-8051 (pins)
	Included with Card	No

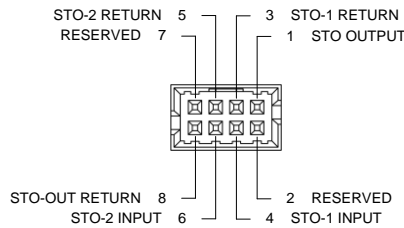



**MOUNTING DIMENSIONS**

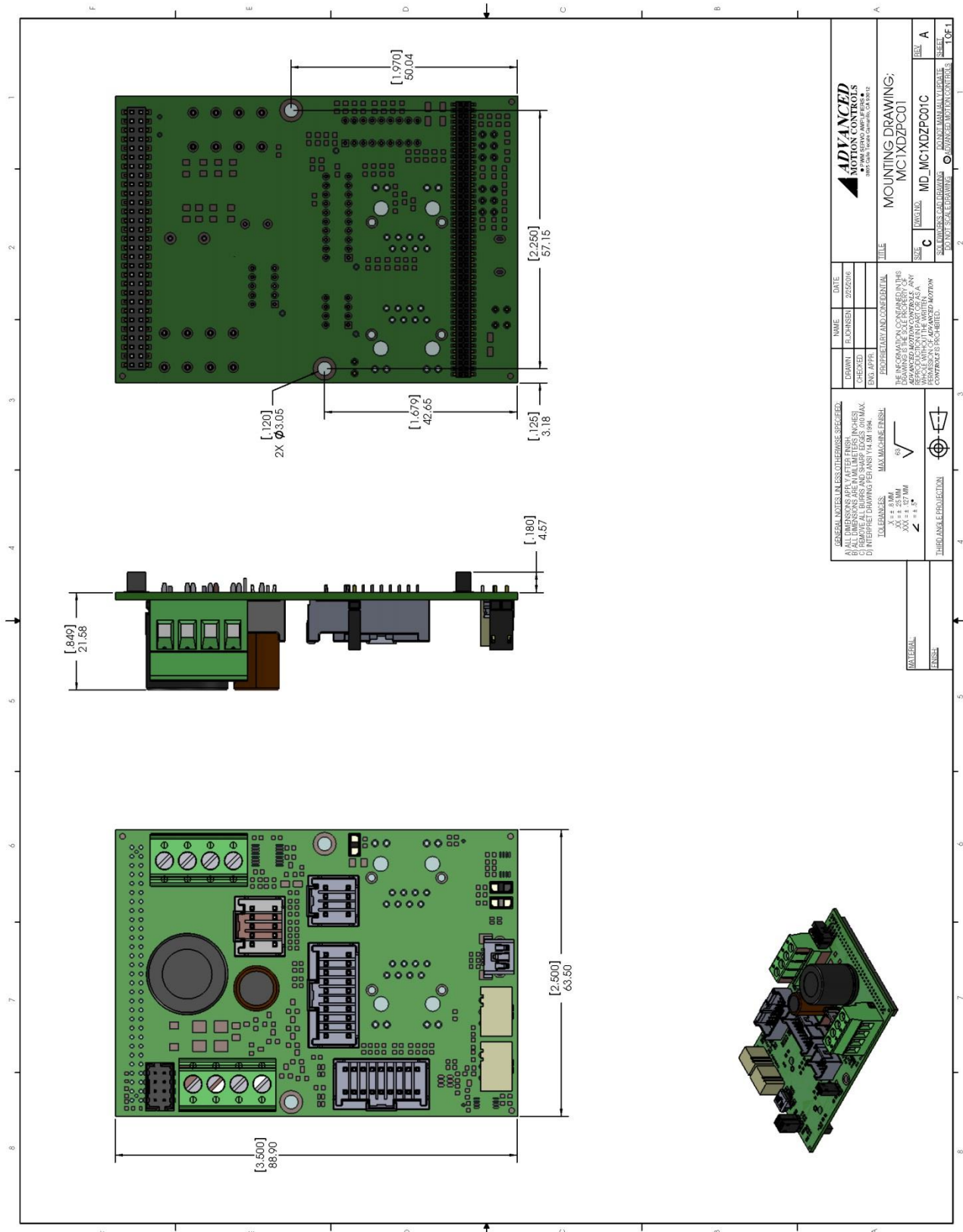

**MOUNTING CONFIGURATION**

Note that a DZCANTU servo drive plugs into the MC1XDZPC01 from the underside of the mounting card to allow easy access to the mounting card switches and connectors. The drive and mounting card assembly can be secured to a panel or heatsink through the mounting holes in the drive baseplate and the sides of the mounting card.

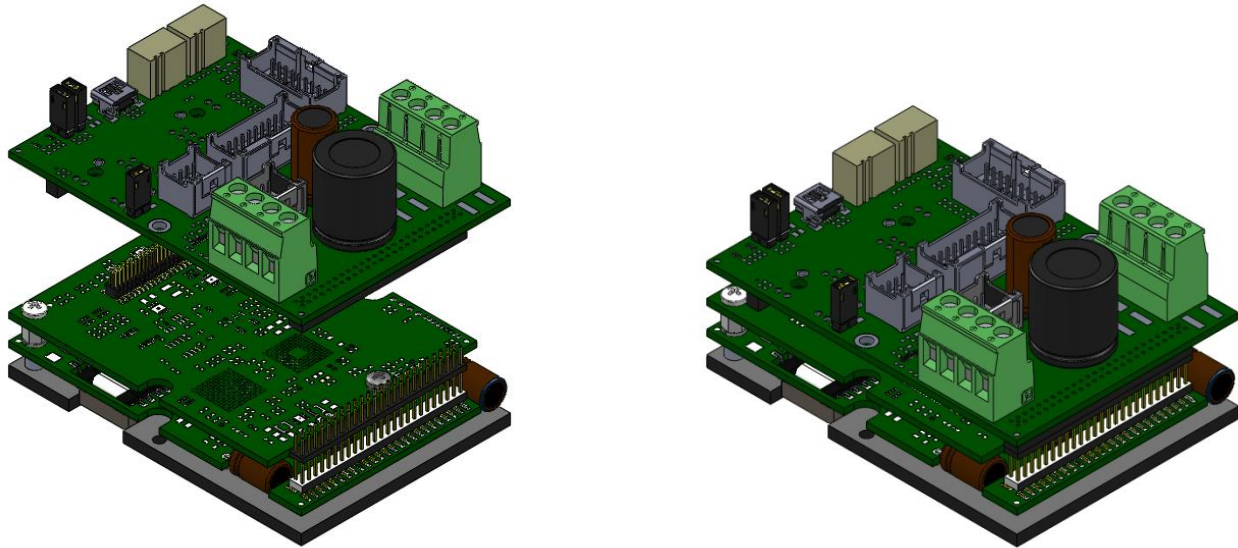

The mounting card chassis should be secured to the drive baseplate by using the two spacers included with the MC1XDZPC01 between the MC1XDZPC01 mounting holes and the drive baseplate as shown in the below image.

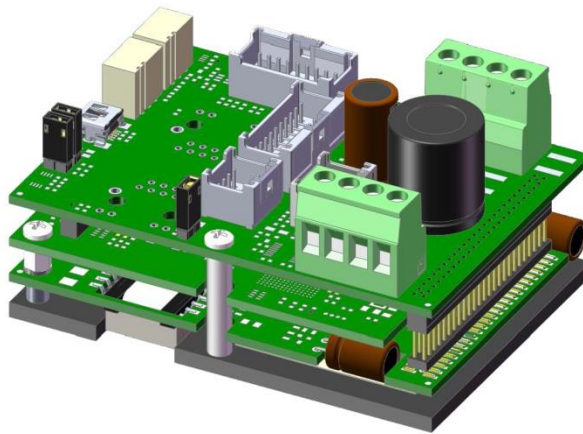

**PART NUMBERING INFORMATION**

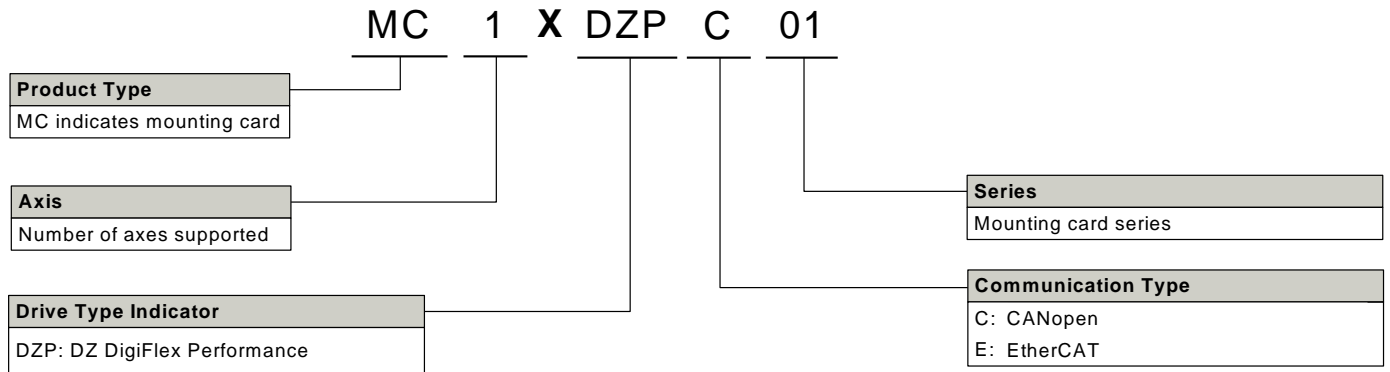

DigiFlex® Performance™ series of products are available in many configurations. All models listed in the selection tables of the website are readily available, standard product offerings.

ADVANCED Motion Controls also has the capability to promptly develop and deliver specified products for OEMs with volume requests. Our Applications and Engineering Departments will work closely with your design team through all stages of development in order to provide the best servo drive solution for your system. Equipped with on-site manufacturing for quick-turn customs capabilities, ADVANCED Motion Controls utilizes our years of engineering and manufacturing expertise to decrease your costs and time-to-market while increasing system quality and reliability.

**Examples of Customized Products**

- ▲ Optimized Footprint
- ▲ Private Label Software
- ▲ OEM Specified Connectors
- ▲ No Outer Case
- ▲ Increased Current Resolution
- ▲ Increased Temperature Range
- ▲ Custom Control Interface
- ▲ Integrated System I/O
- ▲ Tailored Project File
- ▲ Silkscreen Branding
- ▲ Optimized Base Plate
- ▲ Increased Current Limits
- ▲ Increased Voltage Range
- ▲ Conformal Coating
- ▲ Multi-Axis Configurations
- ▲ Reduced Profile Size and Weight

Feel free to contact Applications Engineering for further information and details.

All specifications in this document are subject to change without written notice. Actual product may differ from pictures provided in this document.