

Description

The MC1XDZC03-SHP mounting card is designed to host a DZC series DigiFlex® Performance™ digital servo drive. The drive plugs into the bottom side of the mounting card, providing a compact assembly with connectors and switches readily accessible. The MC1XDZC03-SHP is ideal for prototyping and integrating a DZC series digital servo drive in your machine.

The MC1XDZC03-SHP utilizes side-entry right angle fixed screw terminals for the Motor and Power connectors.

Drive Compatibility**DZ (Standard Environment)****80 V Models**

60A
20A

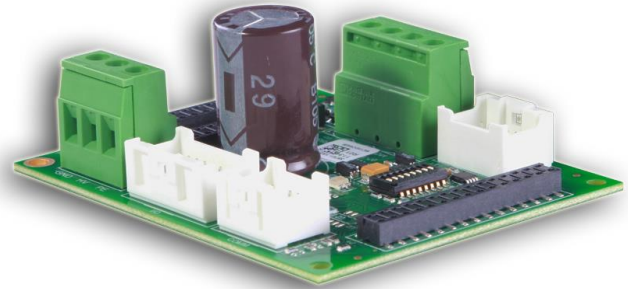
**Features**

- ▲ Mounts DZC-Series DigiFlex® Performance™ Digital Servo Drives
- ▲ Single Axis Mounting Card
- ▲ On-board Signal Conditioning
- ▲ Zener Diode Protected Logic Supply Circuitry
- ▲ On-board DIP Switches for Configuration and Communication Settings
- ▲ On-board CANopen Transceiver for CANopen Communication

DRIVES SUPPORTED

- DZCANTS-060L080
- DZCANTS-020L080

FEEDBACK SUPPORTED

- Incremental Encoder
- Hall Sensors

COMPLIANCES & AGENCY APPROVALS

- RoHS

BLOCK DIAGRAM & SPECIFICATION SUMMARY

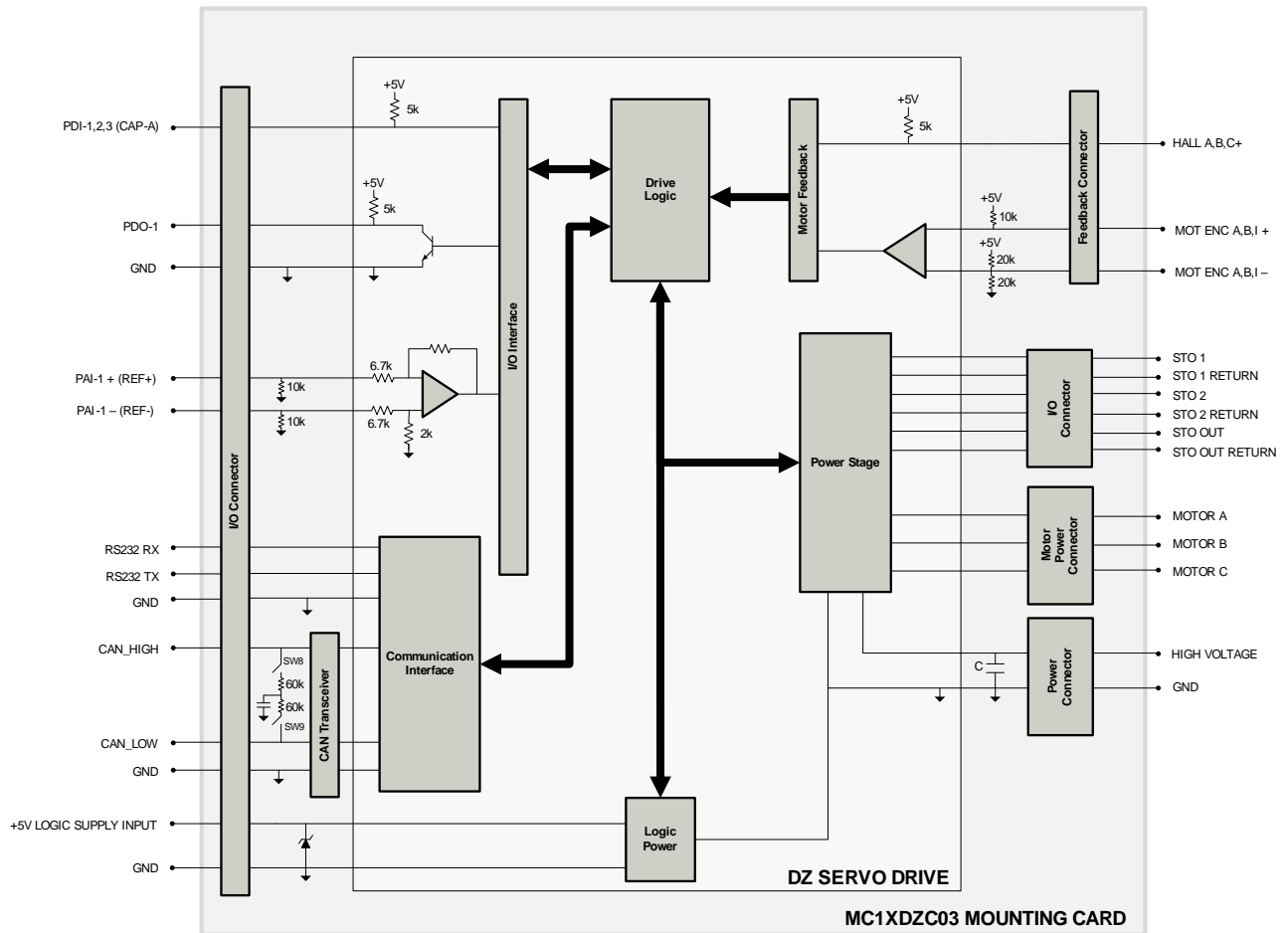

Mechanical Specifications

Mounting Signal Connector: P1	30-pin, dual-row, 2.54 mm pitch socket
Mounting Power Connector: P2	24-pin, dual-row, 2.54 mm pitch socket
Mounting Power Connector: P3	24-pin, dual-row, 2.54 mm pitch socket
I/O Connector: P4*	16-port, dual-row, 2.00 mm spaced plug terminal
Communication Connector: P5*	10-port, dual-row, 2.00 mm spaced plug terminal
Feedback Connector: P6*	12-port, dual-row, 2.00 mm spaced plug terminal
Motor Power Connector: P7	4-port, 5.08 mm spaced fixed screw terminal
Power Connector: P8	3-port, 5.08 mm spaced fixed screw terminal
Bus Capacitance	470 μ F / 100 V
Size (L x W x H) (with drive mounted)	2.5 x 3.0 x 2.1 inches
Weight	50.7 g (1.8 oz)

***Mating Connector Kit**

Mating connector housing and crimp pins can be ordered as a kit using *ADVANCED* Motion Controls part number **KC-MC1XDZ02**. This includes mating connector housing and crimp style contacts for the I/O, Feedback, and Communication connectors. The recommended tool for crimping the contacts is Molex part number **63811-6300**.

PIN FUNCTIONS

P1 – Mounting Signal Connector

This connector mates directly to the drive. For pin functions refer to the drive datasheet.

P2 – Mounting Power Connector

This connector mates directly to the drive. For pin functions refer to the drive datasheet.

P3 – Mounting Power Connector

This connector mates directly to the drive. For pin functions refer to the drive datasheet.

P4 – I/O Connector

Pin	Name	Description	I/O
1	+5V LOGIC	+5V Logic Supply Input. Zener diode assembly protection.	I
2	GND	Ground	GND
3	PDI-3	Programmable digital input 3, or High Speed Capture A	I
4	PAI-1 + (REF +)	Differential reference signal input, 12-bit resolution. Can also be used as programmable analog input 1.	I
5	PDI-2	Programmable digital input 2	I
6	PAI-1 - (REF -)	Differential reference signal input, 12-bit resolution. Can also be used as programmable analog input 1.	I
7	PDI-1	Programmable digital input 1	I
8	STO OUT RETURN	Safe Torque Off Output Return	STORETO
9	GND	Ground	GND
10	STO OUTPUT	Safe Torque Off Output	O
11	STO-2	Safe Torque Off – Input 2	I
12	PDO-1	Programmable digital output 1	O
13	STO-2 RETURN	Safe Torque Off 2 Return	STORET2
14	STO-1	Safe Torque Off – Input 1	I
15	GND	Ground	GND
16	STO-1 RETURN	Safe Torque Off 1 Return	STORET1

P5 – Communication Connector

Pin	Name	Description	I/O
1	RESERVED	Reserved	-
2	RESERVED		-
3	RS232 RX	Receive Line (RS-232) – Connect to TX port on PC	I/O
4	RS232 TX	Transmit Line (RS-232) – Connect to RX port on PC	I/O
5	GND	Ground	GND
6	GND		GND
7	CAN_L IN	CAN_L bus line (dominant low)	I/O
8	CAN_L OUT		I/O
9	CAN_H IN	CAN_H bus line (dominant high)	I/O
10	CAN_H OUT		I/O

P6 – Feedback Connector			
Pin	Name	Description	I/O
1	HALL B	Commutation Sensor Inputs.	I
2	HALL A	Commutation Sensor Inputs.	I
3	MOT ENC A+	Differential Encoder A Channel Input	I
4	HALL C	Commutation Sensor Inputs.	I
5	MOT ENC A-	Differential Encoder A Channel Input (for single-ended signals use only the positive input)	I
6	GND	Ground	GND
7	+5V OUT	+5V Encoder Supply Output	O
8	MOT ENC B+	Differential Encoder B Channel Input	I
9	MOT ENC I+	Differential Encoder Index Input	I
10	MOT ENC B-	Differential Encoder B Channel Input (for single-ended signals use only the positive input)	I
11	MOT ENC I-	Differential Encoder Index Input (for single-ended signals use only the positive input)	I
12	GND	Ground	GND

P7 – Motor Power Connector			
Pin	Name	Description	I/O
1	MOTOR A	Motor phase A	O
2	MOTOR B	Motor phase B	O
3	MOTOR C	Motor phase C	O
4	PE	Protective Earth Ground (motor cable shield)	PE

P8 –Power Connector			
Pin	Name	Description	I/O
1	PE	Protective Earth Ground	PE
2	HIGH VOLTAGE	DC Power Input	I
3	POWER GND	Power Ground (Common with Signal Ground)	GND

BOARD CONFIGURATION

DIP Switch Functions

Drive Address Settings

Node-ID	SW1	SW2	SW3	SW4	SW5	SW6
Load from non-volatile memory	OFF	OFF	OFF	OFF	OFF	OFF
1	ON	OFF	OFF	OFF	OFF	OFF
2	OFF	ON	OFF	OFF	OFF	OFF
3	ON	ON	OFF	OFF	OFF	OFF
...
63	ON	ON	ON	ON	ON	ON

CANopen Bit Rate Settings

Bit Rate (bits/sec)	SW7
Load from non-volatile memory	OFF
125K	ON

CANopen Termination Node Selection

Note that both SW8 and SW9 must be set OFF to terminate the last device on the CAN network.

CANopen Termination	SW8	SW9
Not Terminated	OFF	OFF
Terminated	ON	ON

LED Functions

The MC1XDZC03-SHP contains LEDs that indicate DC Power and Logic power supply status. The Power LED will light up when power is applied to P8-Power Connector, and the Logic LED will light up when the +5 VDC Logic Power is applied to P4-I/O Connector.

Mounting Configuration

Note that a DZ servo drive plugs into the MC1XDZC03-SHP from the underside of the mounting card to allow easy access to the mounting card switches and connectors. The drive and mounting card assembly can be secured to a panel or heatsink through the mounting holes in the drive baseplate, or with standoffs at the four mounting holes in the corners of the mounting card (standoff height must be at least 26.65mm).

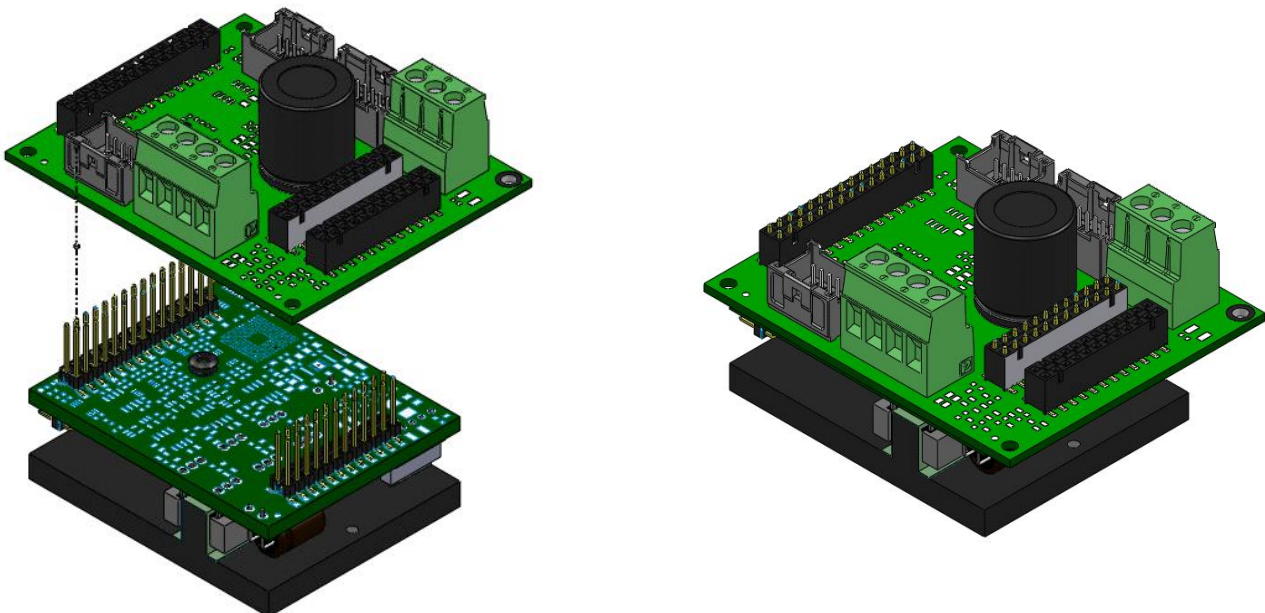

CONNECTOR INFORMATION

P1 – Mounting Signal Connector

Connector Information	30-pin, dual-row, 2.54 mm pitch header
Mating Connector Example	No Mating Connector Required. Mate directly to drive

P2 – Mounting Power Connector

Connector Information	24-pin, dual-row, 2.54 mm pitch header
Mating Connector Example	No Mating Connector Required. Mate directly to drive

P3 – Mounting Power Connector

Connector Information	24-pin, dual-row, 2.54 mm pitch header
Mating Connector Example	No Mating Connector Required. Mate directly to drive

P4 – I/O Connector

Connector Information	16-port, dual-row, 2.00 mm spaced plug terminal, vertical mount	
Mating Connector	Details	Molex: P/N 51353-1600 (housing); 56134-9100 (contacts)
	Included with Card	No

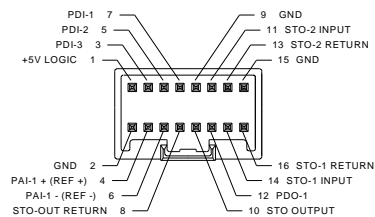

P5 – Communication Connector

Connector Information	10-port, dual-row, 2.00 mm spaced plug terminal, vertical mount	
Mating Connector	Details	Molex: P/N 51353-1000 (housing); 56134-9100 (contacts)
	Included with Card	No

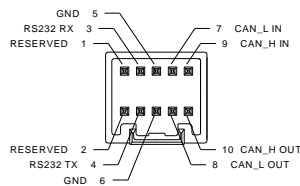

P6 – Feedback Connector

Connector Information		12-port, dual-row, 2.00 mm spaced plug terminal, vertical mount
Mating Connector	Details	Molex: P/N 51353-1200 (housing); 56134-9100 (contacts)
	Included with Card	No

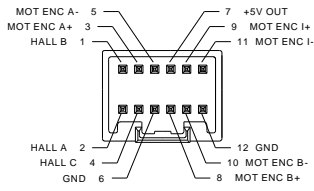

The diagram shows a 12-pin connector with the following connections:
 Pin 1: HALL B
 Pin 2: HALL A
 Pin 3: MOT ENC A+
 Pin 4: HALL C
 Pin 5: MOT ENC A-
 Pin 6: GND
 Pin 7: +5V OUT
 Pin 8: MOT ENC B+
 Pin 9: MOT ENC I+
 Pin 10: MOT ENC B-
 Pin 11: MOT ENC I-
 Pin 12: GND

P7 – Motor Power Connector

Connector Information		4-port, 5.08 mm spaced fixed screw terminal
Mating Connector	Details	Not Applicable
	Included with Card	Not Applicable

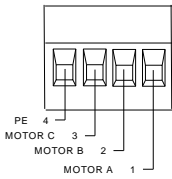

The diagram shows a 4-terminal connector with the following connections:
 Terminal 1: MOTOR A
 Terminal 2: MOTOR B
 Terminal 3: MOTOR C
 Terminal 4: PE

P8 –Power Connector

Connector Information		3-port, 5.08 mm spaced fixed screw terminal
Mating Connector	Details	Not Applicable
	Included with Card	Not Applicable

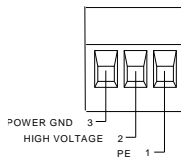

The diagram shows a 3-terminal connector with the following connections:
 Terminal 1: PE
 Terminal 2: HIGH VOLTAGE
 Terminal 3: POWER GND

MOUNTING DIMENSIONS

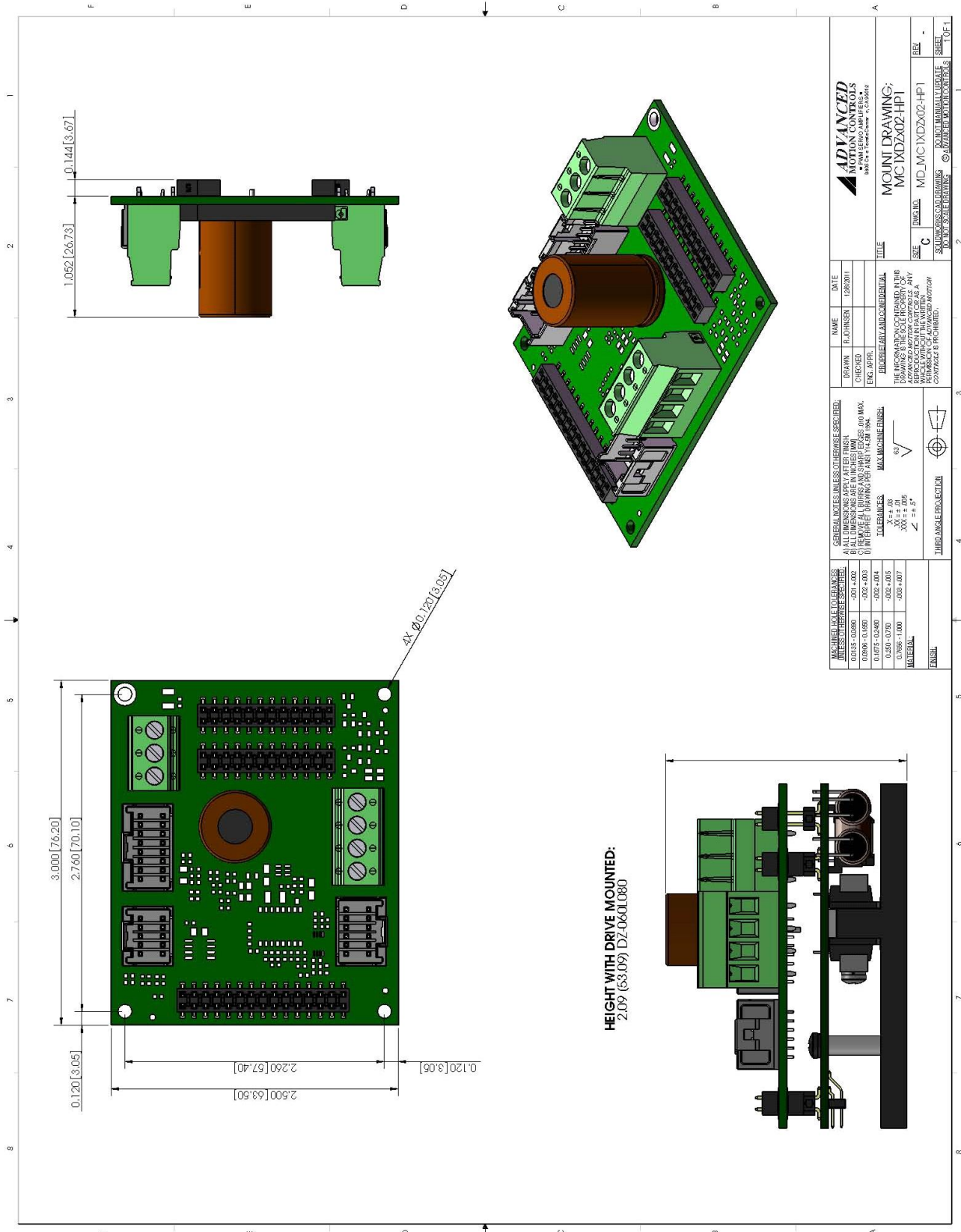

PART NUMBERING INFORMATION

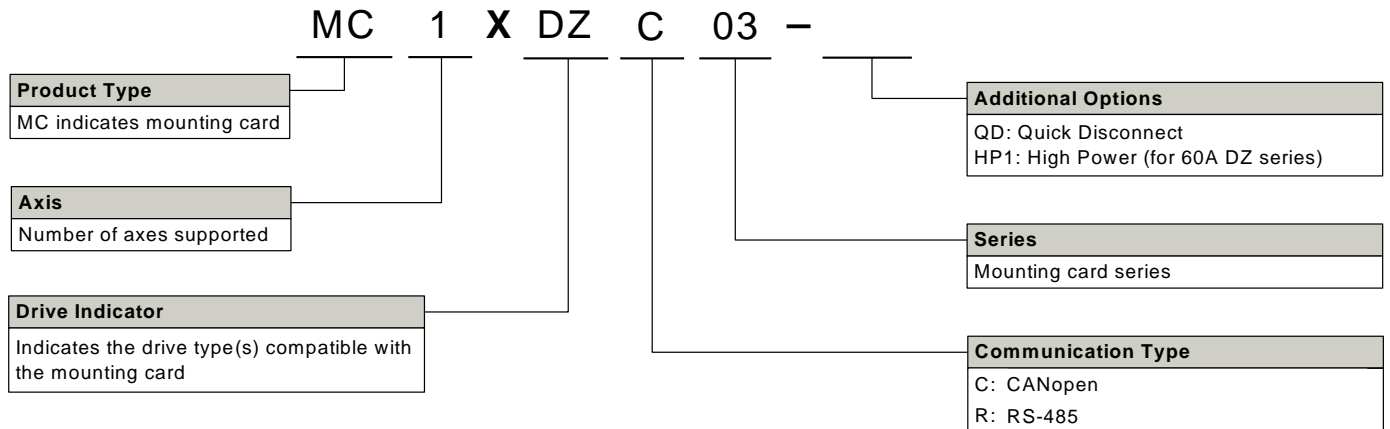

DigiFlex® Performance™ series of products are available in many configurations. All models listed in the selection tables of the website are readily available, standard product offerings.

ADVANCED Motion Controls also has the capability to promptly develop and deliver specified products for OEMs with volume requests. Our Applications and Engineering Departments will work closely with your design team through all stages of development in order to provide the best servo drive solution for your system. Equipped with on-site manufacturing for quick-turn customs capabilities, ADVANCED Motion Controls utilizes our years of engineering and manufacturing expertise to decrease your costs and time-to-market while increasing system quality and reliability.

Examples of Customized Products

- | | |
|--|--|
| <ul style="list-style-type: none"> ▲ Optimized Footprint ▲ Private Label Software ▲ OEM Specified Connectors ▲ No Outer Case ▲ Increased Current Resolution ▲ Increased Temperature Range ▲ Custom Control Interface ▲ Integrated System I/O | <ul style="list-style-type: none"> ▲ Tailored Project File ▲ Silkscreen Branding ▲ Optimized Base Plate ▲ Increased Current Limits ▲ Increased Voltage Range ▲ Conformal Coating ▲ Multi-Axis Configurations ▲ Reduced Profile Size and Weight |
|--|--|

Feel free to contact Applications Engineering for further information and details.

All specifications in this document are subject to change without written notice. Actual product may differ from pictures provided in this document.